

SUBARU WRX

Innovation and success were the end products of the project between COBB tuning, Optimal solutions and Optimal Solutions' European Union distributor, Advantage CFD (now TotalSim), to develop a bodywork package to improve the aerodynamic performance of the COBB Tuning Subaru WRX 2006. The project resulted in the downforce being increased by almost 650lbf when it is at 180kph and 4deg yaw while adding less than 60 lbf of drag.

Trey Cobb, President of Cobb Tuning, was grateful for the OSS assistance:

"Thank you for all the great work Optimal Solutions did to help make this project possible!"

Trey Cobb
President
Cobb Tuning

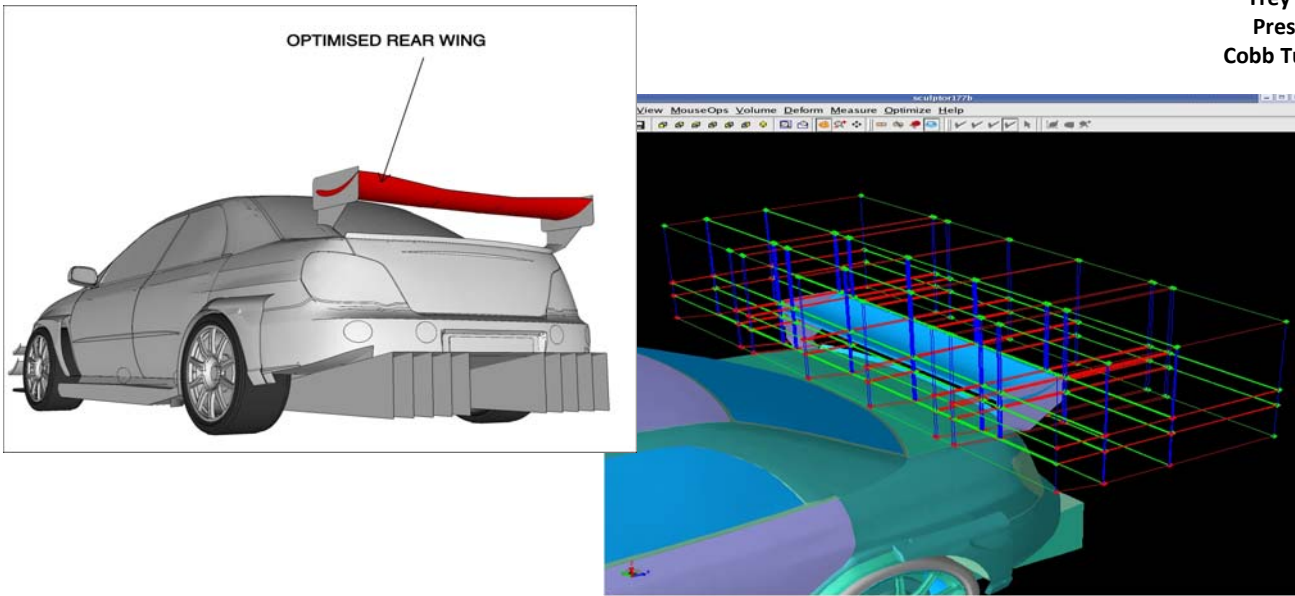

The car raised more than a few eye brows and quickly became the star of the show when COBB debuted the WRX at the Specialty Equipment Market Association (SEMA) 2006 Show held in Las Vegas. Chosen among 41 other "top rides" by the media for "Top Cars and Trucks" at the show, Rob Einaudi, Editor-in-Chief of **CarDomain Network**, the nation's largest media and retail web site for auto enthusiasts, said this about the Subaru WRX car:

"The car is being prepared for time attack competition, and a lot of good work went into the aerodynamics to maximize down force."

Rob Einaudi
Editor-in-Chief
CarDomain Network



The automobile also premiered at the GT Live event on April 28-29, 2007, at the Miller Motorsports Park, voted "Motorsports Facility of the Year", and located in Tooele, Utah.